

**You have
some
costly
problems**



SpiralTracTM

Packing Version



**saves money
in all your fluid
sealing applications**

Problems

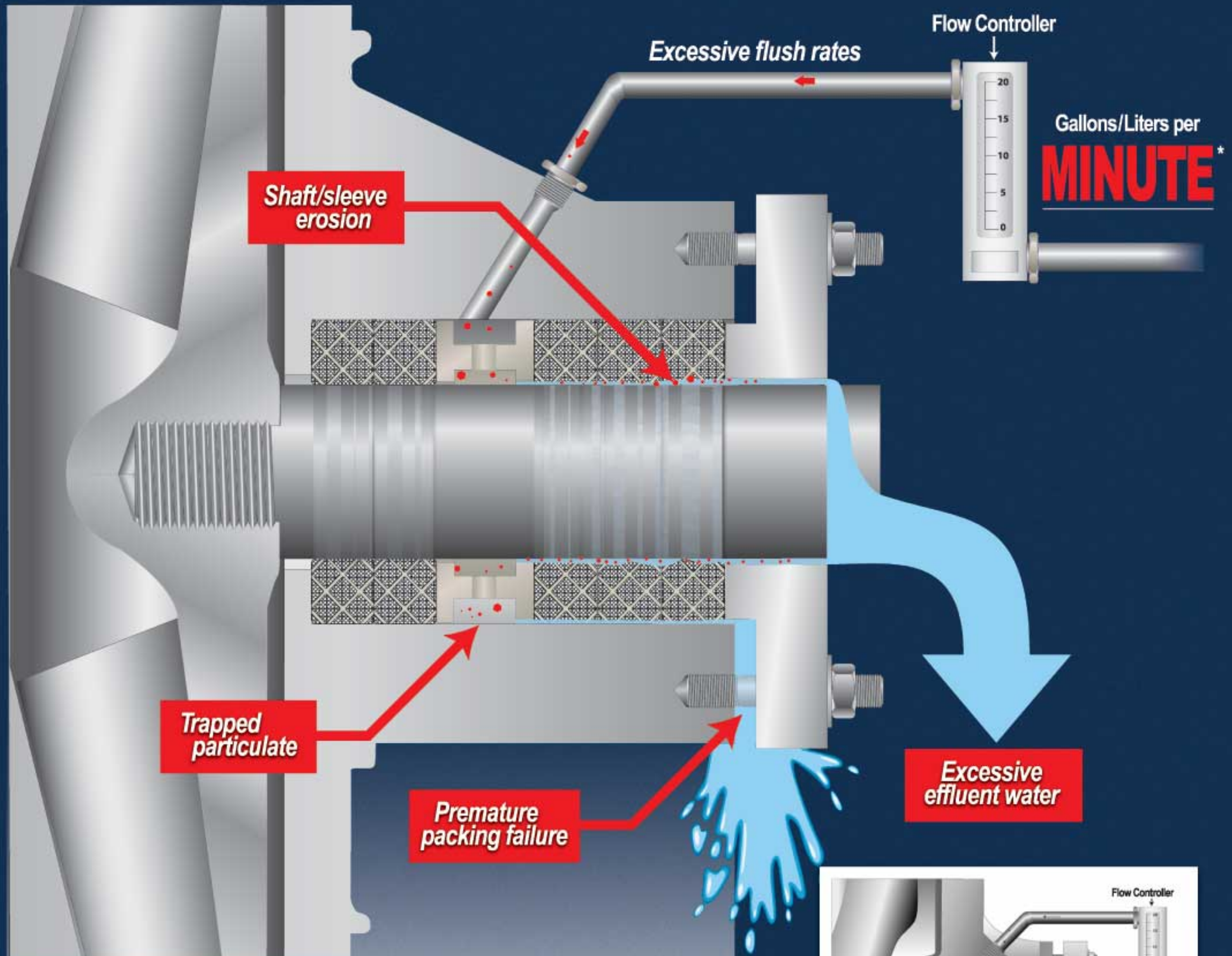

Flush costs

Effluent treatment
Re-heating costs

Maintenance and repair costs

Frequent shaft, sleeve & packing replacement
Labor intensive – time consuming
Housekeeping issues - process leakage

Many equipment types

Different processes – different problems

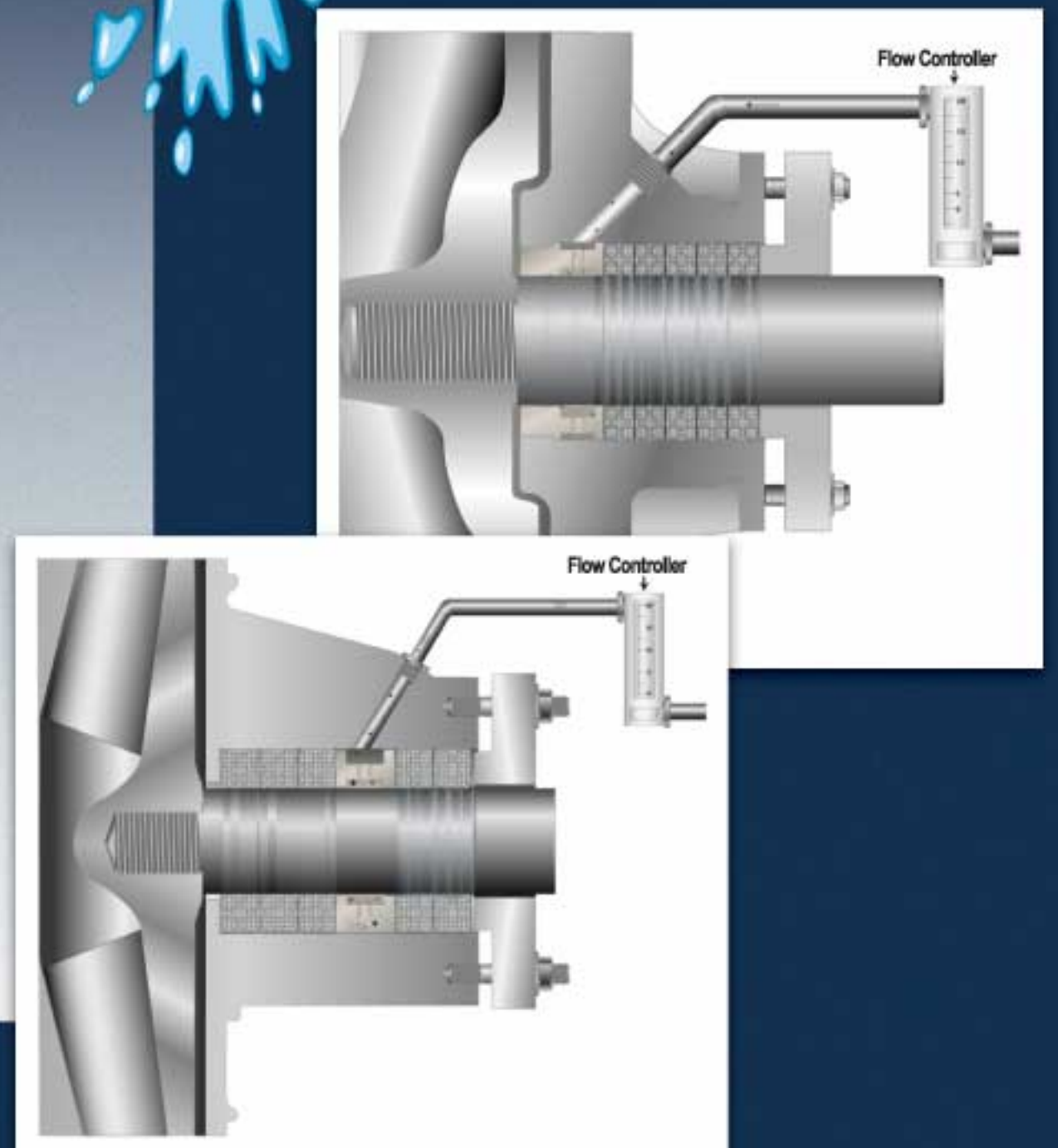

Solution

SpiralTrac

VERSION

P

Flow Controller

Check Valve

Gallons/Liters per
HOUR*

Improves
equipment MTBF

Reduces flush up
to 60% or more*

Reduces leakage
to clean drip rate
or better

Improves packing
performance &
extends packing life

Greatly reduced flush rates

Immediate reduction in
water consumption
Less water = More savings

Greatly improved equipment reliability

Abrasives removed — shaft/sleeve wear minimized
Packing lasts longer — fewer and faster change outs
Clean drip rate = Clean, safe area with no process loss!

Standard and custom designs

Any rotating process equipment can use **SpiralTrac**
Metal or composite construction; solid or
split; single or multistage

* depending on application.

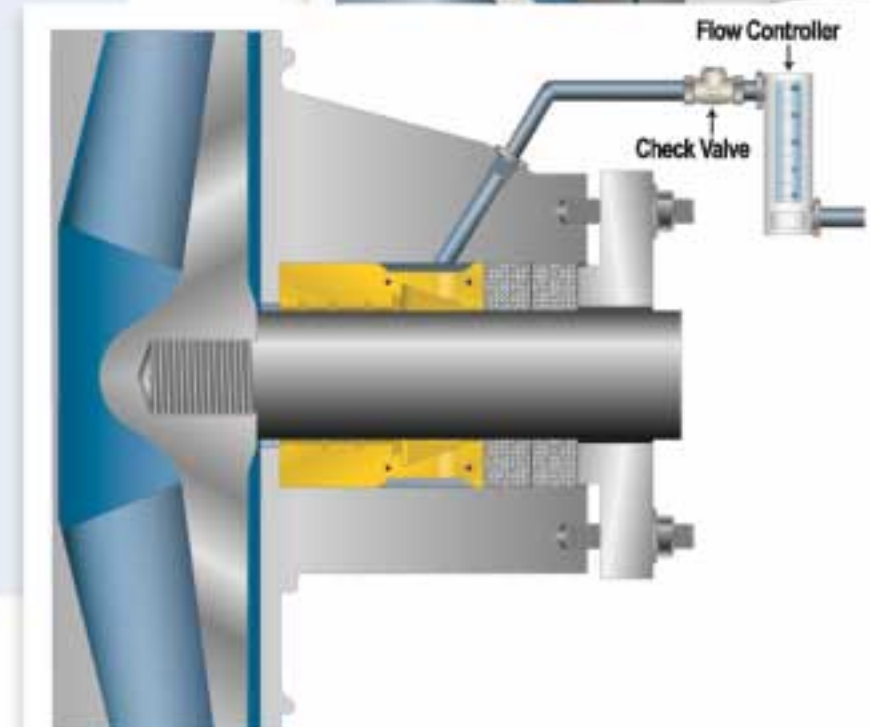
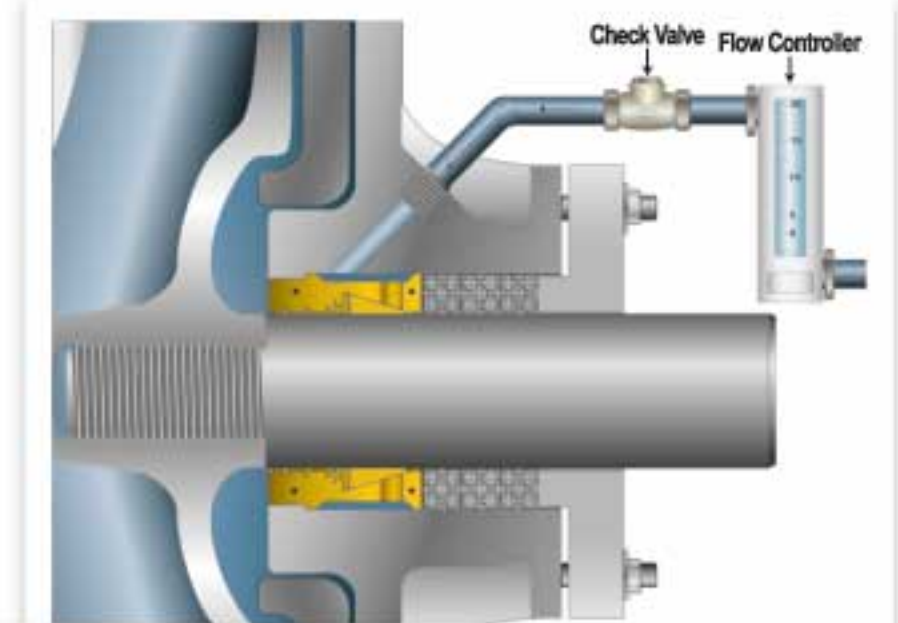

DISTRIBUTED BY

95 Excellence Dr, Wangara WA 6065
Ph: +618 9302 8444
Fax: +618 9302 6186
www.pumpseal.com.au