

## COMPLETE SHAFT SEAL

Air Mizer®

DISTRIBUTED BY

**PUMPηSEAL**  
AUSTRALIA

P: +618 9302 8444  
F: +618 9302 4544

W: [www.pumpnseal.com](http://www.pumpnseal.com)  
E: [sales@pumpnseal.com](mailto:sales@pumpnseal.com)



**INPRO/SEAL**®  
A DOVER COMPANY

# A PERMANENT SOLUTION FOR PRODUCT LOSS AND CONTAMINATION

## Losing More than Product

Product handling applications like mixers, blenders and agitators often suffer from product leakage due to ineffective sealing. In these applications, the powder, liquid or bulk solid migrates down the shaft, through the sealing device and into the atmosphere. This lost product leads to higher production costs, increased maintenance, environmental concerns and unsafe working conditions.

The bottom line...product loss leads to more than just lost product.



Product loss leads to higher production costs, increased maintenance, downtime, and environmental concerns.

## The High Cost of Contact Seals

Packing, mechanical seals and lip seals have been commonly used in an effort to reduce product loss and contamination. All of these methods rely on contact with the shaft to seal the vessel. While they may work well initially, over time they either burn up or groove the shaft at the point of contact; once this happens, the seal is no longer effective and will need to be replaced.

The short and unpredictable service life of contact seals makes them inadequate methods of reliably sealing against product loss. Shaft movement and misalignment have also challenged the sealing methods traditionally used in these slow-speed, low-pressure product handling applications.

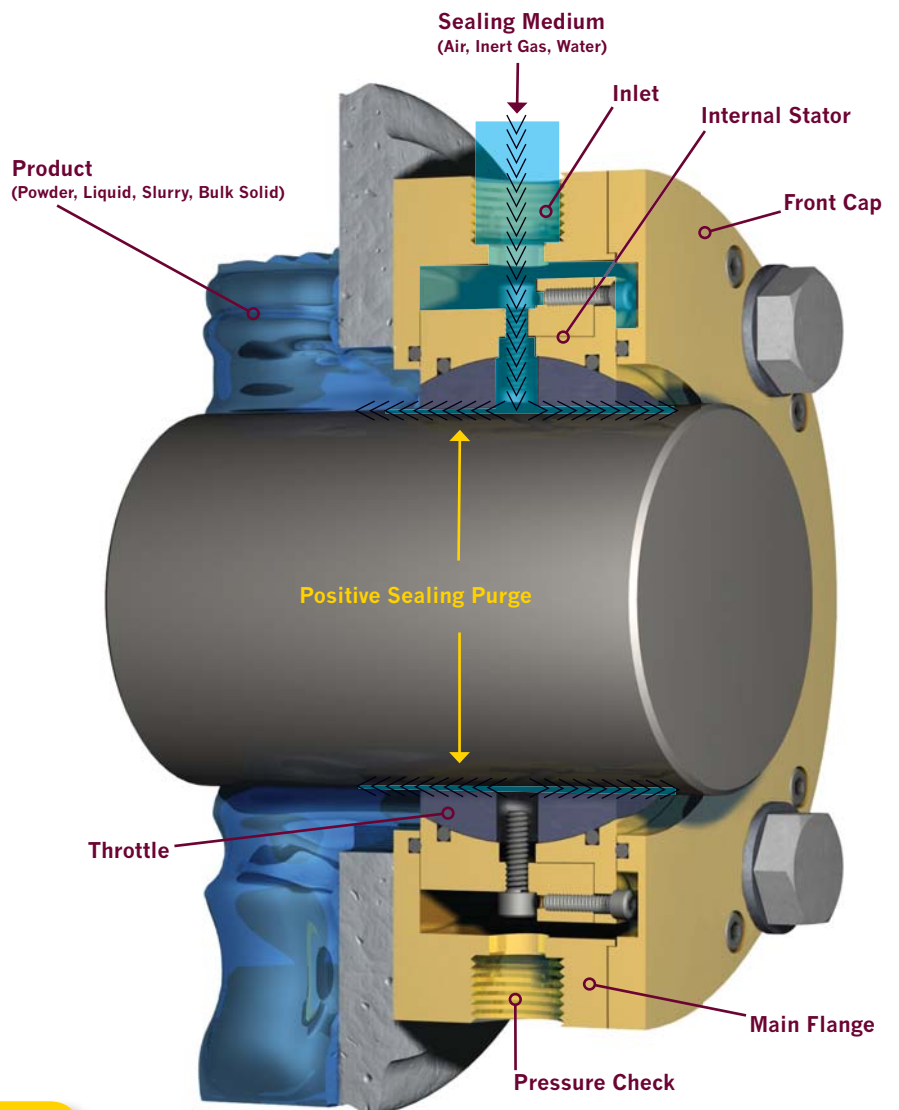

**SPLIT**  
DESIGNS AVAILABLE

SMOOTH BORE



### The Inpro/Seal® Solution

The Inpro/Seal Air Mizer® is a permanent shaft seal that uses a positive purge along the shaft to create an effective seal – preventing product or harmful emissions from escaping into the atmosphere and contamination from entering the vessel. The patented non-contacting, non-wearing Air Mizer is maintenance free and designed to last the lifetime of your equipment.

This unique technology seals by directing small amounts of air, inert gas or water through a precision clearance between the throttle and the shaft, pressurizing the clearance. The air or other sealing medium is evenly dispersed around the shaft to prevent “dead spots” and is directed toward the product and atmosphere equally to safeguard against both product loss and contamination.

Unlike traditional seals, the Air Mizer fully articulates to accommodate radial and angular shaft movement and shaft run-out. It provides an effective shaft seal for powders, liquids, slurries and bulk solids.

#### Benefits:

- Custom engineered for your specific application and operating environment
- Maintenance free, non-contacting, non-wearing, permanent shaft seal
- Split designs available for easy installation
- Minimal amounts of air, inert gas or water required to effectively seal
- Can be installed by OEMs or retrofitted on site
- Accommodates radial and angular shaft movement and shaft runout
- Mounting configurations can be designed for specific applications
- Manufactured in various materials, including bronze and stainless steel, for corrosion resistance and temperature requirements
- Designed for shaft sizes 1.59 – 121.92 cm. (0.625 – 48.0 in.)\*

\* Utilizing special design and material provisions, products can be manufactured to exceed these ranges.

USDA CERTIFIED



CEMA SEAL

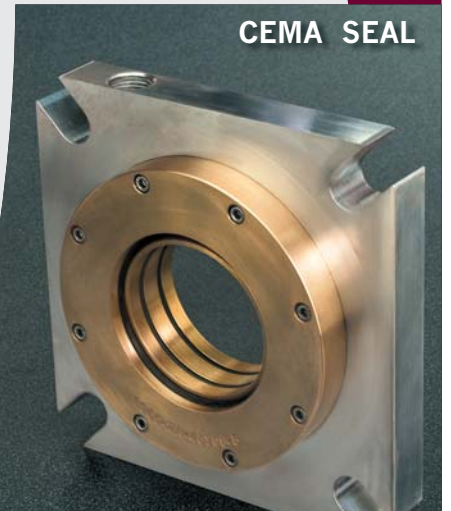

FOOD GRADE

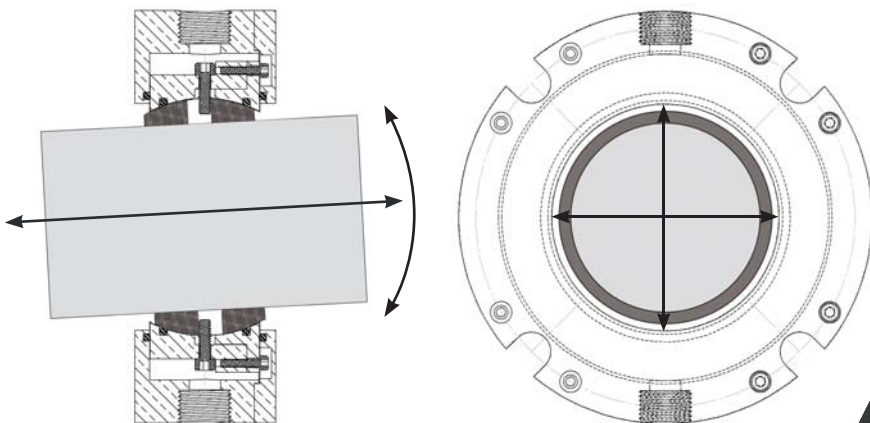

The Inpro/Seal Air Mizer® is designed to handle extreme conditions including radial and angular shaft movement and shaft runout



# GUARANTEED PERFORMANCE

The Inpro/Seal® Air Mizer® is backed by an unconditional performance guarantee. See our website for complete details.

## Unmatched Customer Service

Inpro/Seal's responsive global sales network is committed to making sure you have the right technology for your application, right when you need it. We know that time means money for you. That's why we offer the shortest lead times in the industry, even on new designs. No matter what your application, we can deliver a custom engineered solution designed to meet your specific needs.

**Technology you can rely on, supported by customer service you'll appreciate.**



The stainless steel food grade Air Mizer® and USDA certified Air Mizer meet the most stringent specifications in the food and beverage industry.

## A Universal Solution

The Inpro/Seal® Air Mizer® is a permanent shaft seal for mixers, blenders, agitators, rotary feed valves, screw conveyors, pulpers and other product handling equipment. This technology has been applied across a variety of industries including chemical processing, food and beverage, mining, power generation, processing and pulp and paper.

No matter the size or complexity of your application, Inpro/Seal can engineer an Air Mizer to fit your exact specifications.

## Experience You Can Trust

Permanent shaft seals require a custom engineered solution that takes into account all these factors:

- Operating equipment
- Product type
- Temperature conditions
- Mounting configurations
- Shaft movement
- Shaft to bore misalignment (STBM)
- Material specifications

You don't need to be an expert; our knowledgeable team will help. You can count on Inpro/Seal, the leader in bearing and system protection, to maximize the uptime of your product applications. We've been the trusted source for sealing technology in rotating equipment for more than 30 years and have installed countless permanent shaft seals in industries worldwide.

## The Inpro/Seal Advantage

Inpro/Seal is committed to delivering innovative technology and superior customer support...standard with every solution. When you work with Inpro/Seal, you can expect:

- Custom engineered solutions for your application and operating environment
- Knowledgeable sales network providing localized support
- Unconditional performance guarantee – see website for complete details

DISTRIBUTED BY



P: +618 9302 8444      W: [www.pumpnseal.com](http://www.pumpnseal.com)  
F: +618 9302 4544      E: [sales@pumpnseal.com](mailto:sales@pumpnseal.com)

The Inpro/Seal® Air Mizer® is a custom engineered solution and some designs may be protected by both US and foreign patents and pending patent applications including US Pat. 7,090,403; 7,396,017; 7,631,878 and 7,727,661.



[www.inpro-seal.com](http://www.inpro-seal.com) | [info@inpro-seal.com](mailto:info@inpro-seal.com) | +44 141 424 4122